

The Demag wheel range | Innovative series-produced components for travel units with wheel loads up to 60,000 kg

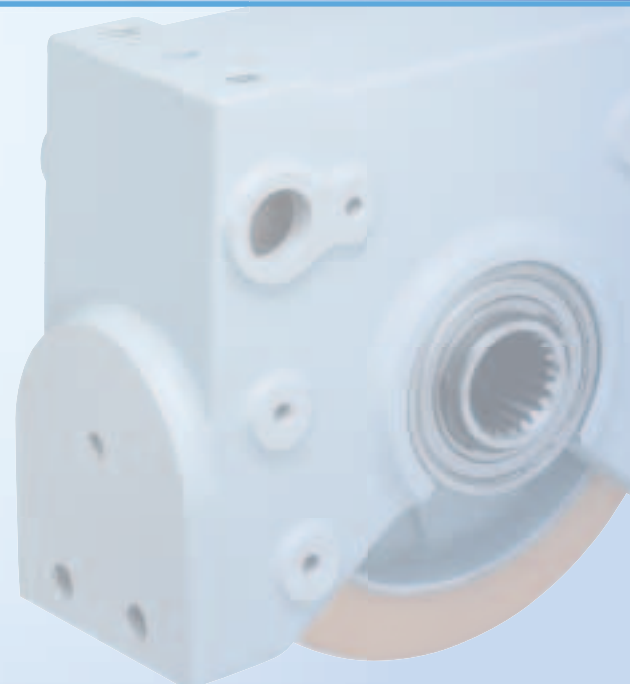

The right solution for every application

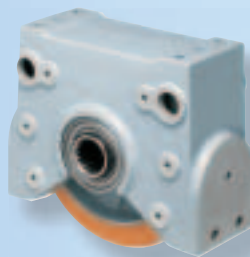
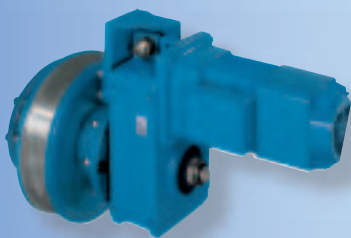

6

Demag DRS wheel block system

14

Demag LRS travel wheel system

16

Demag RS wheel block system

18

Demag RAE/RNE wheel sets

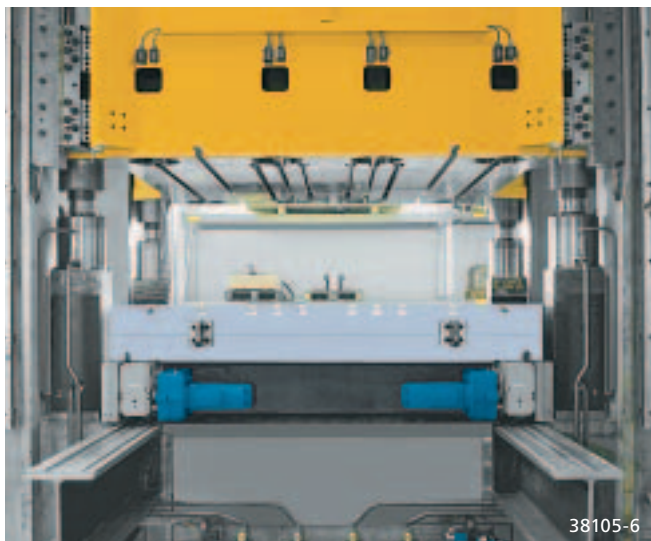

For decades, Demag Cranes & Components has been designing and manufacturing modular wheel systems for a wide variety of applications.

The broad range covers wheel loads up to 60,000 kg and offers

- simple selection
- wide range of combinations
- favourable dimensions
- versatile connection possibilities to the customer's design
- design support by means of CAD files
- simple assembly and alignment

Demag wheel units are integral components of countless mobile devices and systems in operation every day, offering high reliability and a long service life with a minimum maintenance requirement.

Complete travel units

Complete units offer decisive advantages for drive applications. All components – from the travel wheel, housing and connecting arrangement to the gearbox, motor and frequency inverters for electronically controlled travel – are perfectly

matched and pre-assembled ready for fitting. They offer you the certainty of solid planning and investment.

Including application expertise

With the extensive expertise gained from wheel block applications in installations and systems we have built all over the world, we provide our customers with help and advice on their applications. We provide state-of-the-art selection and design tools and calculation programs and project engineering support for the given application requirements.

All over the world

Wherever your products are used, the many agencies and countless service stations operated by Demag Cranes & Components guarantee a reliable supply of spare parts and provide expert repairs.

Serving the needs of industry

There is hardly a manufacturing industry in which raw materials, semi-finished products and finished products do not have to be transported, merged, transferred, distributed or assembled.

In many applications, special operating conditions and functional requirements have to be taken into consideration. Demag wheel systems meet the demands of any application with ease and are therefore the first choice for any materials handling solution.

Reliable solutions

If required, wheel blocks can be protected by special design measures against aggressive media, for example, or they can be fitted with electronically controlled drives, which enable them to accelerate even more quickly, travel at uniform speeds and position with precision. Demag wheel systems ensure that floor-level travel units and systems can also negotiate tight curves with radii down to 10 m. Demag wheel systems also operate just as well indoors as outdoors.

The right wheel for every application

The use of matching components designed on the modular principle enables Demag travel unit components to be employed quickly and effectively for both standardised as well as tailored solutions. Every component used is developed, designed and tested in-house for unbeatable functional reliability, continuously optimised and manufactured in large series of first-class quality and with maximum precision.



DRS

The DRS wheel block system

is a versatile wheel block system with optimum performance ratios for a maximum load capacity – from 2.75 t to 40 t – with compact dimensions. Finely graded sizes (DRS 112 to DRS 500) ensure that the right DRS unit is selected for the corresponding application.

A wide variety of travel wheel designs are available from the standard range to meet customer requirements. The housing, which is machined on all sides, can be connected to virtually any customer design.

Offset and angular geared motors from the Demag modular system are available for the driven variant as individual or central drive units.

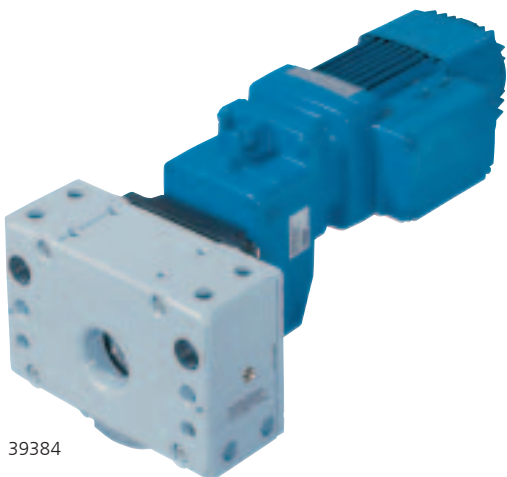

39384

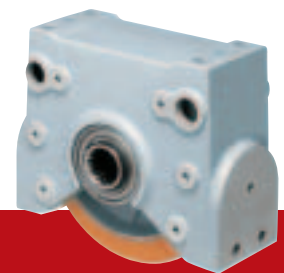

LRS

The LRS travel wheel system

is a robust, universal travel wheel system for the lower load range up to 6.5 t. Simple selection makes it the ideal assembly for engineers who want to build their own solution for a wide variety of travel applications.

Two standard designs for each size – travel wheel with Hydropur tyre and a spheroidal graphite cast iron travel wheel with two flanges – are available pre-assembled from stock and can be supplied in a minimum of time.

Standard offset geared motors can be assigned by means of selection tables for driven designs.

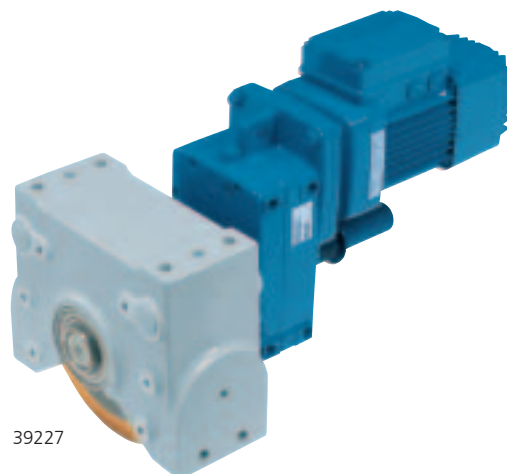

39227

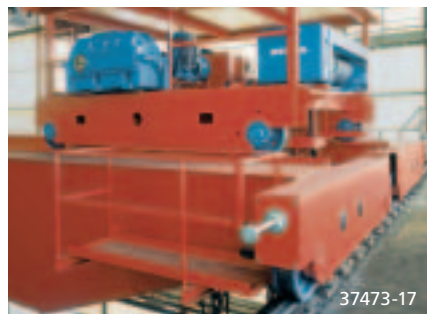

RS



The RS wheel block system

is suitable for special applications in which a stainless design or a housing made of sheet steel is required, as well as for high temperature applications (up to 350 °C). Various RS 125 to RS 400 sizes can be supplied with load capacities from 3.5 t to 18 t.

Various travel wheel designs and means of connection to customer structures also make this standard component suitable for universal applications.

Demag offset geared motors can be used as drive units.

RAE/RNE



RAE/RNE wheel sets

are the right choice for applications in the highest load range. Sizes can be supplied with travel wheel diameters of 400, 500 and 630 mm with load capacities from 28 t to 60 t.

A travel unit consists of a driven RAE wheel set and a non-driven RNE wheel set and is designed to be installed in hollow profile sections or as corner bearing units.

Demag offset geared motors are ideally suited as drives.

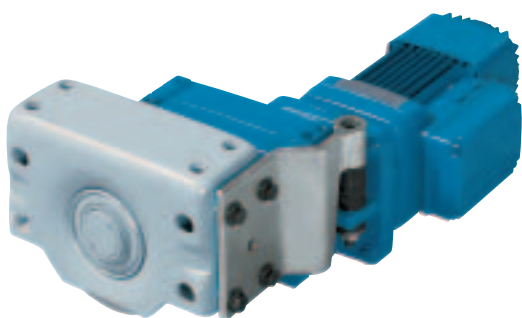

39383

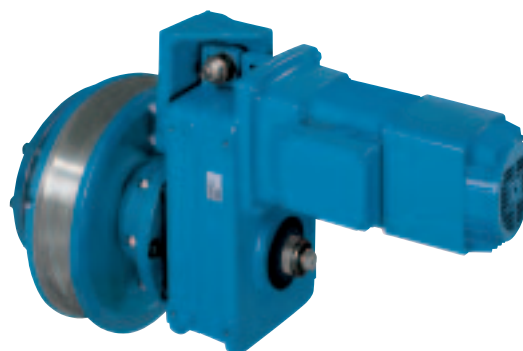

39398-2

Versatility and high performance – Demag DRS wheel block system

The Demag DRS wheel block system offers outstanding benefits – from project engineering to commissioning of your installation. The wheel blocks are excellent solutions for a wide variety of applications. They also offer particularly high performance, i.e. a maximum load capacity with reference to the diameter of the spheroidal graphite cast travel iron wheel.



Exact dimensions

The tight design and position tolerances of the housing and corresponding precise geometry in all planes ensure that Demag wheel blocks can be easily fitted to your installation, with starting and braking characteristics which are gentle on the runway. In addition, special stiffeners guarantee high rigidity.

Fully enclosed

The housing, which is enclosed on five sides, protects the travel wheels from external mechanical influence.

For DRS sizes 112 to 200, the housing is of high quality, corrosion-resistant, die-cast aluminium with a powder coating up to 90 µm thick. From size DRS 250, high-tensile spheroidal graphite cast iron with a RAL 7001 finishing coat is used. Any openings that are not required can be closed with the plugs included in the delivery.

Wheel variants

The system features wheels of various designs and shapes, made of spheroidal graphite cast iron or featuring Hydropur tyres. The driven travel wheel design differs from non-driven wheels by a splined engaging profile of various diameters to DIN 5480.

Simple prevention

A residual flange marking clearly indicates when the spheroidal graphite cast iron travel wheel with flange has to be replaced. Together with the next regular inspection, this helps to guarantee the availability of the installation through preventive maintenance.

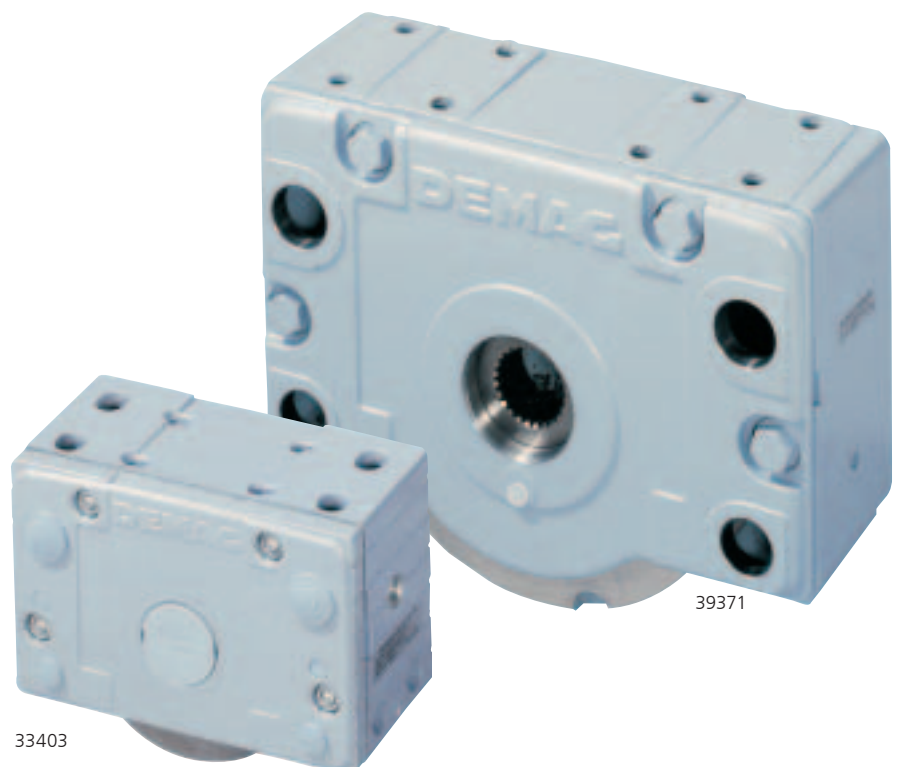
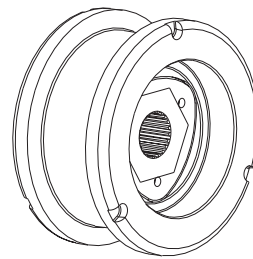



Low maintenance

The travel wheels feature generously dimensioned grooved ball bearings, and tapered roller bearings from size DRS 250, which are lubricated for life. Arranged inside the housing, the bearings have optimum protection against mechanical influences.

Simple wheel replacement

The patented asymmetrical housing eliminates the need for time-consuming removal and realignment of top-mounted wheel blocks when travel wheels have to be replaced. The housing remains connected to the installation. This job can be completed using conventional tools. The wheel blocks can also be converted just as quickly and easily at a later date and fitted with travel wheels of a different design or material.

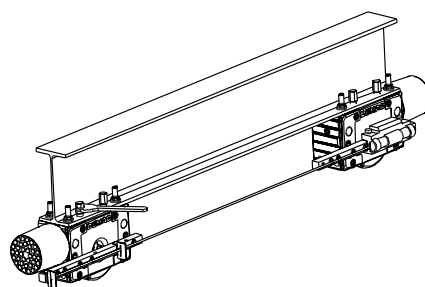

The right direction

Demag has developed a laser alignment system to eliminate any problems in aligning wheel blocks. Together with prepared brackets on the housing and eccentric pins which fit into slots in the top of DRS 112 to DRS 200 wheel blocks, this system makes it possible to align wheel blocks mounted on multiple trolleys rapidly and exactly in line with each other.

Clearance

Of particularly compact design, DRS wheel blocks feature high ground clearance. This also applies to complete drive units with their gearbox concept designed to match the wheel load.

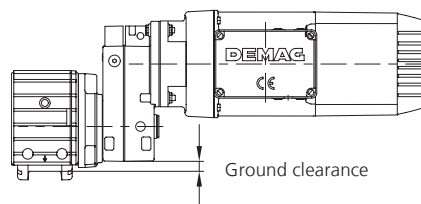

Patented superiority

The Demag DRS wheel block system features numerous new and, in part, patented design solutions such as the torque bracket, the travel wheel bearing arrangement, the travel wheel hub connection, the sliding nuts in the top connection (DRS 112 to DRS 250), and also the housing design.

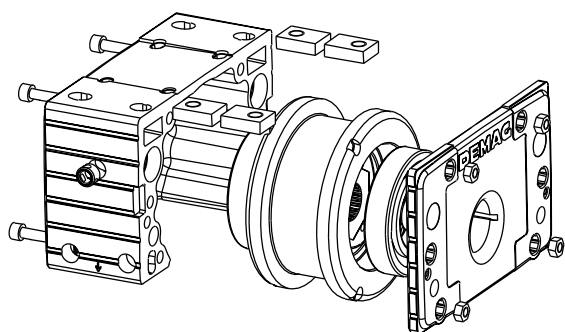

Modular system for tailor-made solutions

Whatever you plan and build, be it a new installation or the modernisation of an existing facility – the Demag DRS wheel block system with its wide variety of perfectly matched components will meet all your requirements. The right wheel blocks and drive units can be supplied for every application: tailored to meet your needs, compact and reliable.



Perfect shape

Demag DRS wheel blocks can be matched to many different types of travel rail and operating conditions with travel wheels from a wide range of standard designs or with specially developed travel wheel profiles.



Travel wheels guided by flanges on both sides, with generous wear reserves for common rail systems or with a tread to your specifications



Wheels for guided applications in vertical and horizontal planes of prismatic or trapezoidal design or with a concave tread ...

Travel wheel types and materials

With effective vibration-damping characteristics, the spheroidal graphite cast iron (GGG 70) travel wheels guarantee high-speed operation which is particularly gentle on the rail. The self-lubricating effect of the wheel material reduces friction and provides high resistance to wear. These properties make spheroidal graphite cast iron travel wheels far superior to conventional steel travel wheels.



Travel wheels without flanges, if required with guide rollers for rigidly guided systems

...and also spheroidal graphite cast iron wheels with a convex tread or of hardened design

Also available are Polyamide travel wheels without flanges, which offer particularly smooth and quiet running properties and are gentle on the runway. Flangeless travel wheels fitted with Hydropur tyres, which also provide for smooth operation at high acceleration rates, complete the travel wheel range.



Travel wheels guided by a flange on one side for units running at floor level, also with a central flange for special requirements



Flangeless travel wheels with a Hydropur tyre for high acceleration and quiet running characteristics



Large diameter travel wheels without a flange for increased ground clearance



Polyamide travel wheels without a flange for quiet running and gentle on the runway

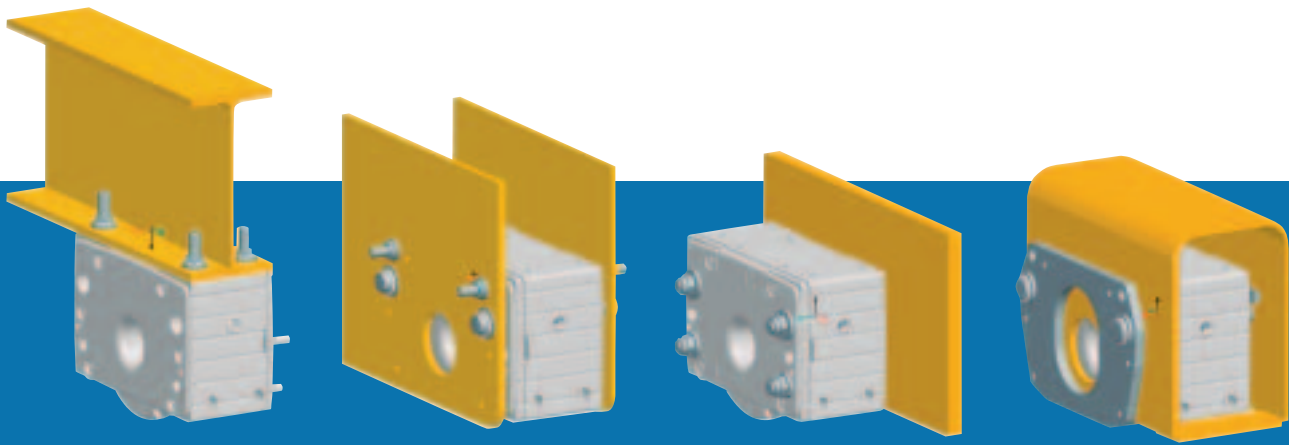

Top connection

Pin connection

Side connection

End connection

Connection variants

An important feature of Demag wheel blocks are the prepared mounting surfaces which facilitate virtually any connection arrangement – ranging from top and end connection arrangements with bolted and welded connection elements, to side and pin connection arrangements for installation in hollow sections and cross beams. Top, end and pin connection arrangements make it possible to move and align the wheel blocks laterally even after they have been fitted.

Guide forces

Tailored solutions are also available for guiding wheel blocks. Flange-guided travel wheels and wheels with prism-shaped or concave treads for round cross section rails provide for exact vertical and horizontal guide arrangements. If strong horizontal forces have to be reliably absorbed, infinitely adjustable guide rollers with a positive connection should be used.

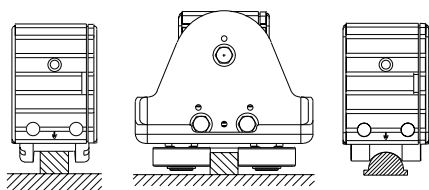

Dimensions

(DRS with spheroidal graphite cast iron wheel with two flanges)

DRS wheel block Size	Max. load capacity kg	Travel wheel Ø mm	Weight kg	Dimensions in mm				
				a1	b1	b2	c1	h1
DRS 112	2750	112	7,3	190	47	80	96	131
DRS 125	5000	125	9,9	220	60	80	98	147,5
DRS 160	7000	160	18,3	275	65	89	110	187
DRS 200	10000	200	35,7	340	65	101	130	238
DRS 250	16000	250	62	385	75	110	150	281
DRS 315	22000	315	117	470	90	130	180	349,5
DRS 400	30000	400	201	580	110	155	210	440
DRS 500	40000	500	352	700	110	170	240	566

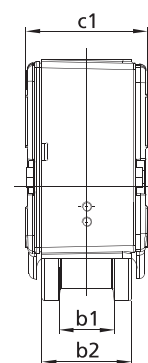
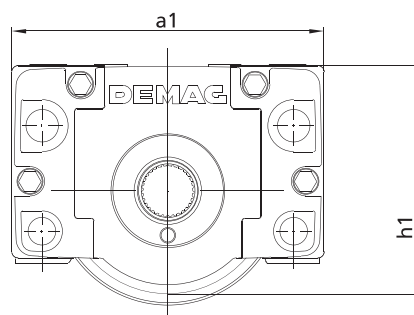

Options and accessories

Horizontal guide roller arrangements as well as buffers are available in various sizes and designs.

The right drive

Demag drive system components consisting of motors and gearboxes as well as inverters for particularly smooth and precise acceleration, braking and positioning are precisely matched to the Demag wheel range. The perfect combination of all components turns installations into efficient systems.

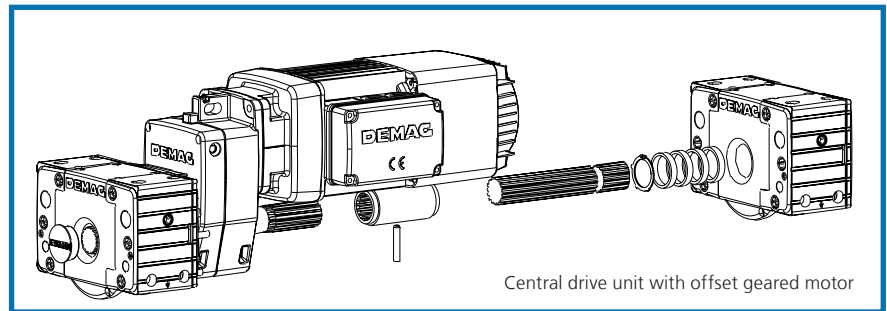

The direct drive input variant with a cylindrical rotor motor and additional flywheel is characterised by a shallow torque curve. The additional flywheel, arranged close to the offset or angular gearbox, also provides an optimum centre of gravity for the drive.

The coupling connection variant has the advantage that it can also be driven by our high performance conical rotor brake motors with their high starting frequency and braking capacity for very demanding stopping and starting applications.

The drives can also be designed with one motor to drive two wheel blocks. These central drive arrangements guarantee absolute synchronous operation of the wheel block pairs.

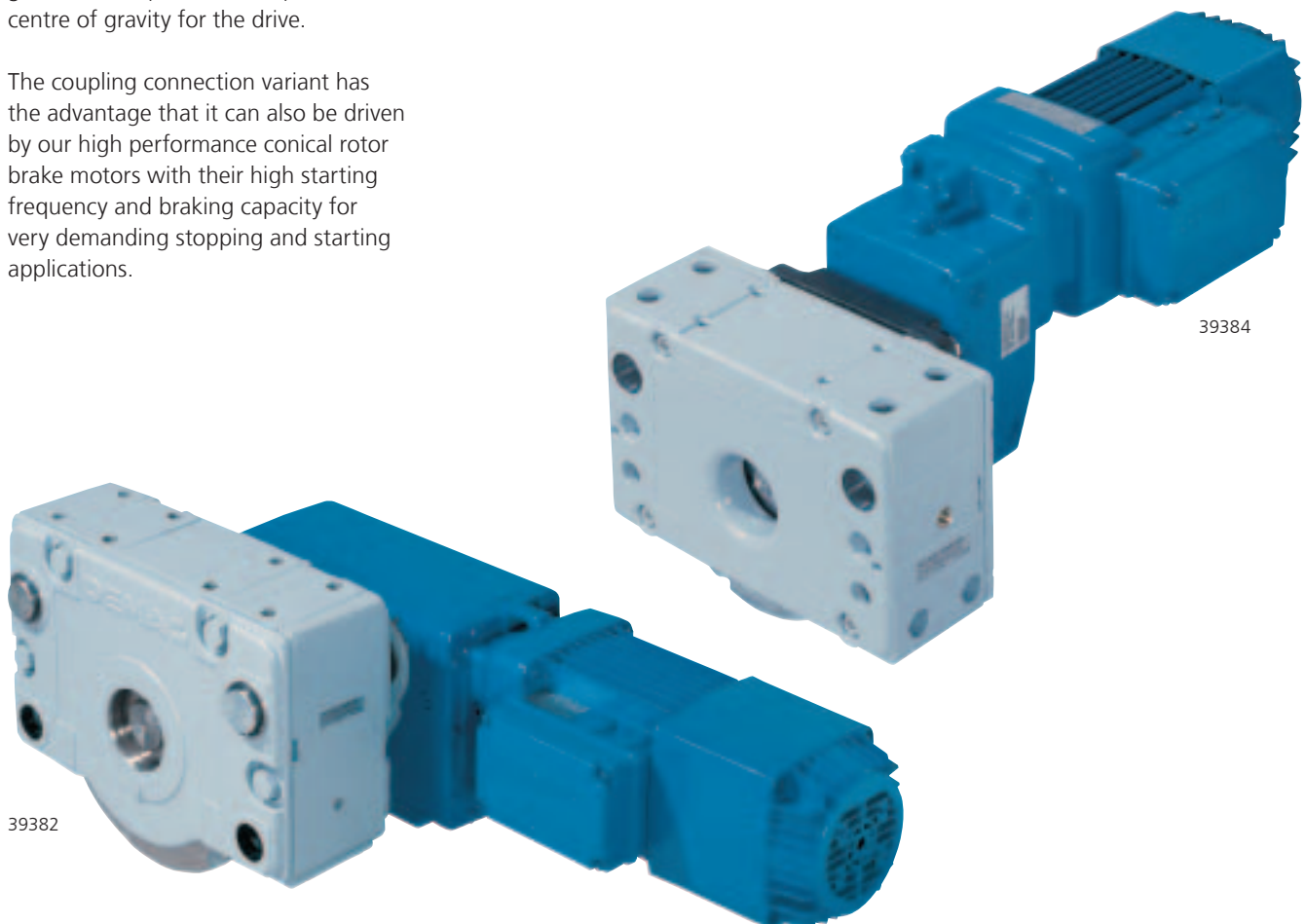

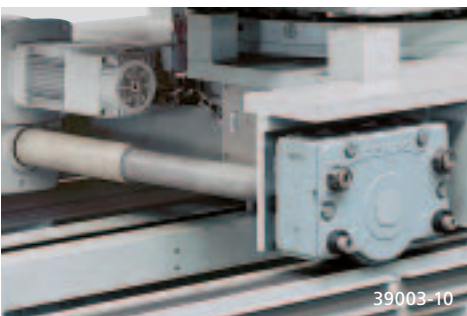

39003-10



38350-1



39271-4

In combination with the relevant torque bracket, the integrated torque ring cast into the housing cover of our offset gearboxes makes it possible to fix the drive in various positions relative to the DRS wheel block – in 15° steps to provide an optimum fit of the drive into the connecting structure.

Furthermore, the patented torque bracket enables the torque to be transferred from the geared motor to the wheel block without any radial forces, which reduces the load on the drive shaft and extends its service life.

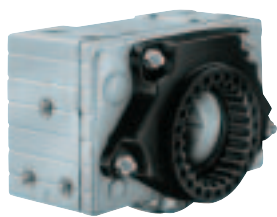

36754

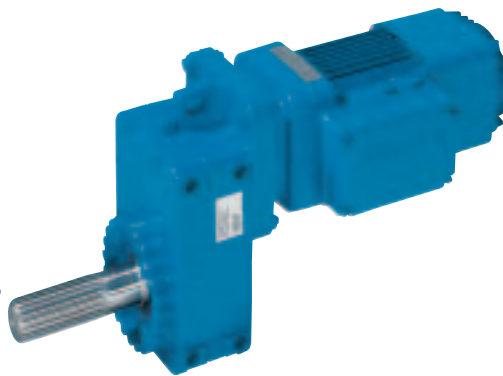

39392



39379-2



39380-1

In addition to the special Demag travel motors for line-fed operation – also as pole-changing units for two speeds – we offer standard drive motors with frequency inverters for electronically controlled operation, e.g. also for exact positioning at minimum speeds. There are two ranges: Dedrive Compact for motor outputs up to 30 kW and Dedrive Pro for motor outputs up to 560 kW.

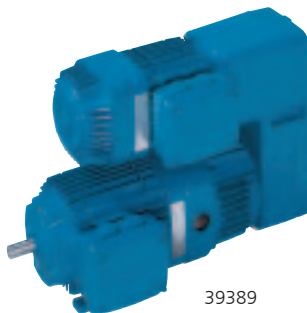

39389

Demag microspeed drives are the optimum solution if a wide ratio is required between the “positioning speed” and “fast speed”. They can be used to achieve transmission ratios of up to 1:500 with line-fed drives without the need for an inverter.

Practical project engineering support – Drive Designer online

Drive Designer online provides optimum support for project engineering and design. It facilitates rapid access to technical data and drawings of Demag wheel blocks and geared motors via the Internet. Use it as a configurator, for project engineering support and for enquiries.



Selection of the required wheel blocks is usually based on the planned load capacity. The speed at which a particular mass needs to be transported is also decisive.

The corresponding components of a 4-wheel carriage are specified by entering the known parameters, such as the temperature range, cycle times, rail type and materials. The result is a complete, distinct type code. Any required options can also be selected. A data sheet shows all relevant technical data.

You can generate the corresponding dimension diagrams and product geometry details in the usual CAD formats for the selected combinations. Circuit diagrams show the electrical connections for the motor.

In addition to the configuration of complete 4-wheel carriages, travel units consisting of one, two, four or more wheel blocks can be individually designed and configured. This method allows both offset gearboxes and angular gearboxes to be selected. When the configuration has been specified, the wheel blocks can be ordered direct in Demag Shop at www.demag-shop.com.

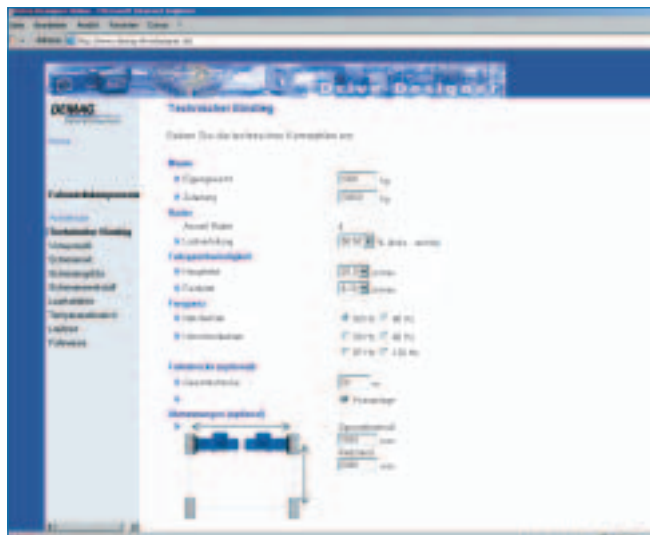

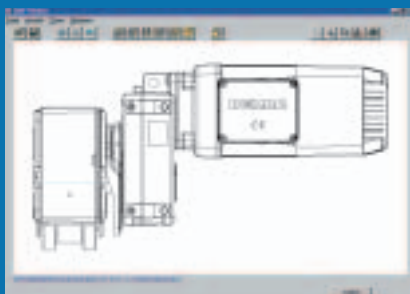

Individual 2D CAD files

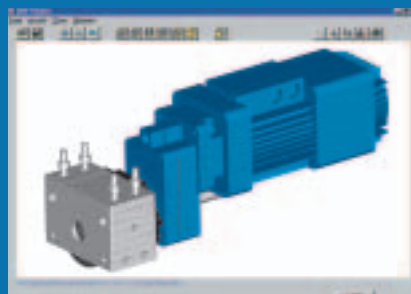

3D product geometries

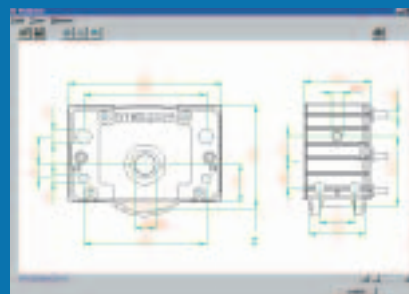

Complete dimension drawings

Calculate the right drive with CalDrive

The required output, loads and speeds need to be entered into Drive Designer to select travel units. Alternatively, the travel unit can be selected on the basis of the complete mounting code.

In contrast to Drive Designer, the required drive data is calculated from the specified physical characteristics using CalDrive calculation software.

The basic characteristics and data of Demag geared motors and wheel blocks are included in CalDrive. Drives for travel and hoist applications, as well as for roller, chain or belt conveyors can be specified with ease. The program suggests solutions for the combination of our offset, angular and helical gearboxes with cylindrical or conical rotor motors. You can also determine drive solutions for line-fed or frequency inverter systems, of course. Besides the technical data, you are also shown acceleration and deceleration values in the result.

You can request the current version of the multi-lingual CalDrive calculation program on CD-ROM free of charge at www.drives.demagcranes.com.



Universal solution for loads up to 6.5 t – Demag LRS travel wheel system

The Demag LRS travel wheel system is a robust, universal travel wheel system for a wide range of applications. It is the solution for travel applications with wheel loads up to 6.5 t (at 100 m/min) and travel speeds up to 240 m/min.

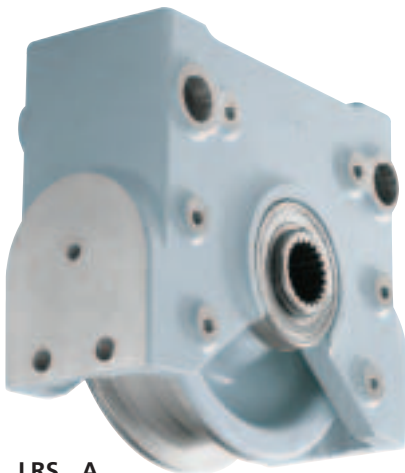
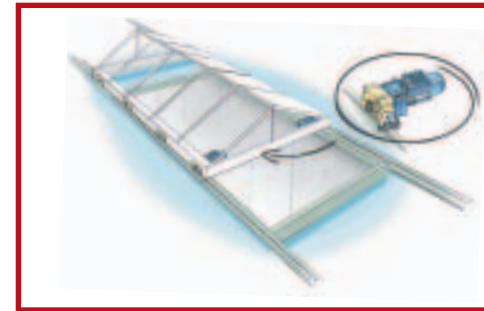
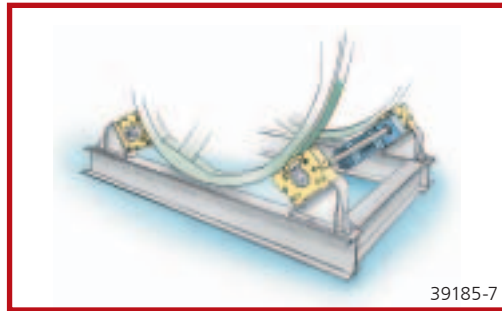

LRS...A

39366-2

The LRS system requires virtually no maintenance and is suitable for operation at ambient temperatures from -20 °C to +60 °C. The five precisely machined connecting surfaces of the extremely rugged spheroidal graphite cast housing block offer a wide range of connection variants. It is fitted with top-connection bolts as standard. The LRS travel wheel system is available in two designs: LRS...A with a spheroidal graphite cast iron travel wheel and two flanges with a high load capacity and good rolling and damping characteristics and LRS...F as a travel wheel with a Hydropur tyre for very good traction and low operating noise.

Also with drive

Demag offset geared motors are ideally suited as travel drives for the Demag LRS travel wheel system. The gearbox is connected to the LRS system with a hollow shaft featuring involute splines (to DIN 5480) by means of a shaft system and a matching torque bracket. Various gearbox sizes are available with corresponding travel motors depending on the load to be moved and the required speed. The selection tables show pole-changing geared motors for line-fed operation (400 V, 50 Hz).

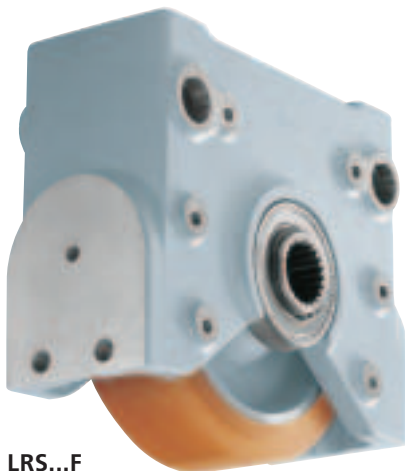

LRS...F

39364

Also available as optional accessories: a pin connection set, a buffer set, horizontal guide roller arrangement and central drive unit set for track gauges of 1,500 mm and 2,900 mm.

Two individual drive units

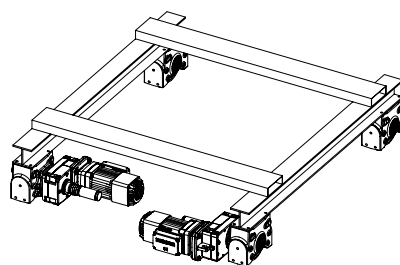

Central drive unit

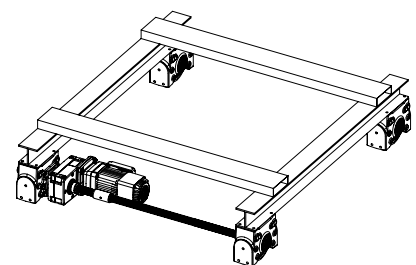

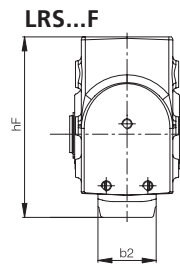
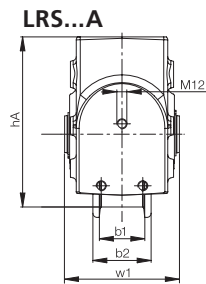
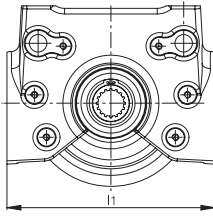

39185-4

39185-2

Dimensions

LRS travel wheel system Size	Travel wheel	Max. load capacity kg	Travel wheel Ø mm	Weight kg	Dimensions in mm					
					l1	w1	hA	hF	b1	b2
LRS 200	A	2500	175	15,3	250	138	204,5	242	52	70
	F	1200	200	15,1					-	70
LRS 250	A	3500	220	27,6	306	156	255	270	55	80
	F	1700	250	26,7					-	80
LRS 350	A	6500	315	63,0	450	200	359,5	367	65	95
	F	3000	350	65,0					-	110

From CAD model to convenient online order

To facilitate integration of the selected LRS components into your design, we offer 2D and 3D files in various formats online at www.lrs.demagcranes.com. Choose your CAD format after selecting the required components.

The following formats are available:

- 2D CAD files: DXF1), DWG
- 3D CAD files: IGES, STEP, Pro/Engineer (2001)
- Dimension sheets: PDF

¹⁾ The DXF Viewer is available free of charge to view the files.

You can either reserve or order the required component parts direct, specifying the delivery date as well as the shipping method.

When you have ordered the components, we will immediately advise our order number and the calculated delivery date.



www.demag-shop.com

2D-CAD-Files



3D-CAD-Files

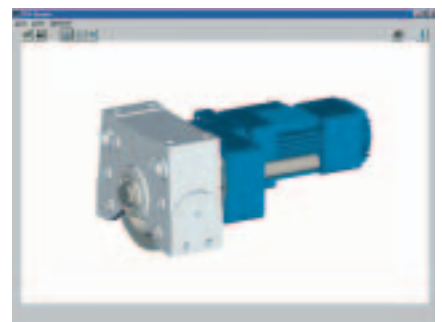

The solution for special requirements – Demag RS wheel block system

The RS wheel block system consists of a housing welded together from two sheet steel halves with an integrated travel wheel. It can be attached to customer structures with ease using the prepared connecting surfaces. The varied connection possibilities make it simple to add it to existing installations at a later date.



Main RS features

- load-bearing block enclosed on 5 sides with connecting surfaces featuring multiple bore holes
- reamed lateral bore holes for the pin connection
- integrated connections for torque brackets, guide roller arrangements and buffers
- steel housing primed and finished with a top coat in RAL 7001
- long service life of the steel and mechanical elements
- rapid installation and removal for all connection variants
- wide variety of standard travel wheel designs

For particularly tough applications

The special designs for high temperature applications up to 150 °C or with furnace carriage bearings up to 350 °C are a special feature of the RS wheel block system.

The RS 125 size is available in stainless steel. It is particularly suitable for applications in the chemical industry, the foodstuffs sector and in aggressive environments.

Drive

The gearbox has a hollow shaft featuring involute splines on the output side. The positive connection to the travel wheel shaft guarantees reliable torque transfer, which is specially important for

reversing and intermittent operation. The drive torque is transferred either direct to the wheel block by means of a D1 torque bracket or via the connecting structure using a D2 torque bracket.

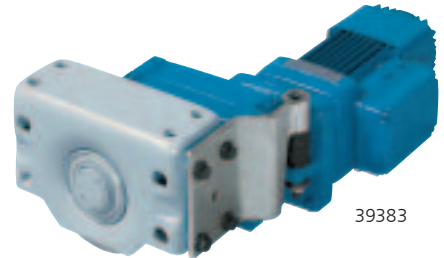
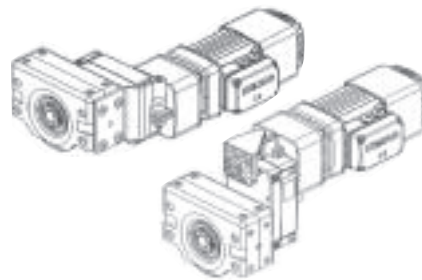



Dimensions

(RS with spheroidal graphite cast iron wheel with two flanges)

RS wheel block Size	Max. load capacity kg	Travel wheel Ø mm	Weight kg	Dimensions in mm				
				a ₄	l ₅	h ₇	b ₁	b ₂
RS 125	3500	125	8,0	220	98	148	60	68
RS 160	5000	160	15	275	110	187	60	75
RS 250	9000	250	40	385	150	281	65	100
RS 315	12000	315	65	470	180	350	65	110
RS 400	18000	400	153	580	210	440	80	140

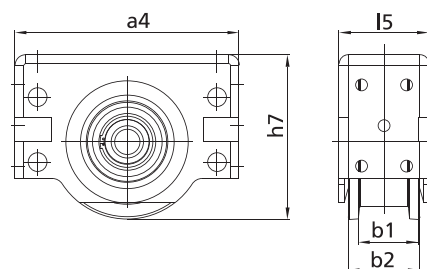

Connection variants

Top connection

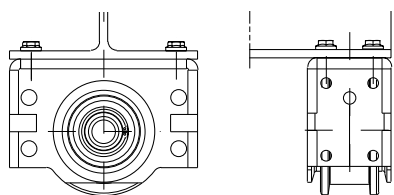

Side connection

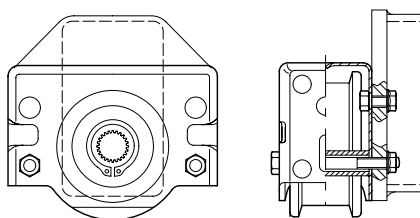

Pin connection

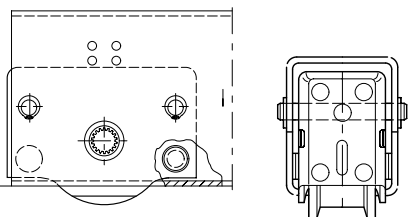

End connection

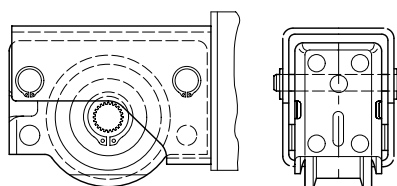

The right solution for heavy loads – Demag RAE/RNE wheel sets

Demag travel units are used for rail-guided travel applications in the heavy load range. A complete travel unit consists of a non-driven RNE wheel set and a driven RAE wheel set. Demag offset geared motors are used as drive units.



The use of these proven series-manufactured components offers a high level of functional reliability and guarantees interchangeability when the wheel is replaced. Owing to their versatility and many potential applications, RAE/RNE travel units are not only used in the cranes and materials handling sector, but also for related mechanical engineering solutions.

The wheel sets can be installed in hollow profile sections and box girder sections and as corner bearing units. Corner bearing arrangements offer the advantage of installing a pre-assembled wheel set in a travel unit without the need for extensive alignment. The unit can be rapidly replaced without the need for any alignment work, which ensures a high level of availability.

Fitted in hollow profile section

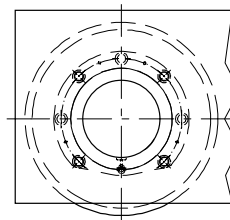

Corner bearing arrangement

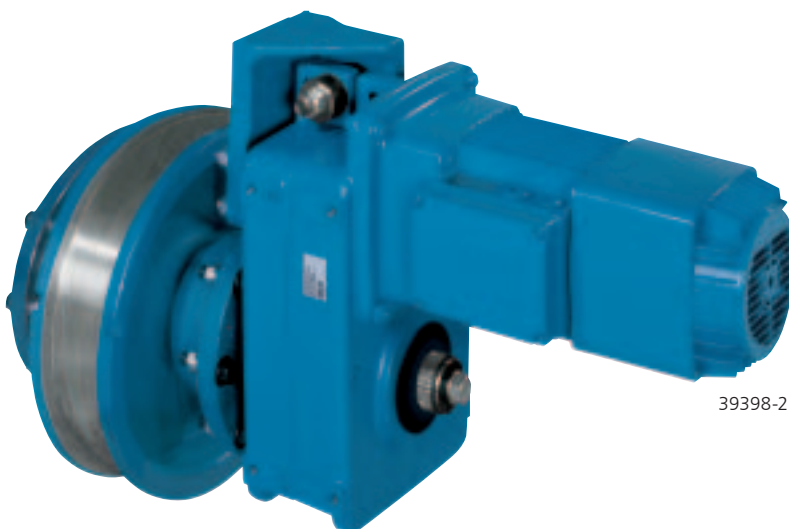
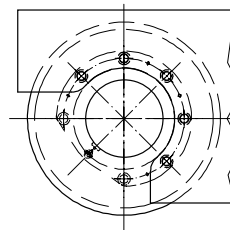

Drive

Demag AUK/ADK offset gearboxes with Z motors with direct drive input or also with a coupling connection are used as the drives for RAE wheel sets.

The D2 torque bracket is fitted direct to the supporting structure.



38323-13



37473-17



38174-5



Design features

- simple track gauge compensation thanks to interchangeable distance washers between the anti-friction bearings and retaining rings
- rapid installation and removal of the travel wheel from the travel unit using conventional tools
- long service life thanks to standard re-lubrication facility
- driven design matched to Demag offset geared motors
- guide flange wear indicator
- flange bearings provided with notches for applying extractors.

Dimensions

RAE/RNE wheel sets Size	Max. load capacity kg	Travel weight Ø d1 mm	RNE weight kg	Dimensions in mm				
				l ₅	l ₆	d ₂	b ₁ *	b ₂
RAE/RNE 400	28000	400	105	280	362	437	80 80	125 140
RAE/RNE 500	40000	500	142	320	402	537	90 104	140 170
RAE/RNE 630	60000	630	310	350	456	680	75 110	140 170

* Special treads on request

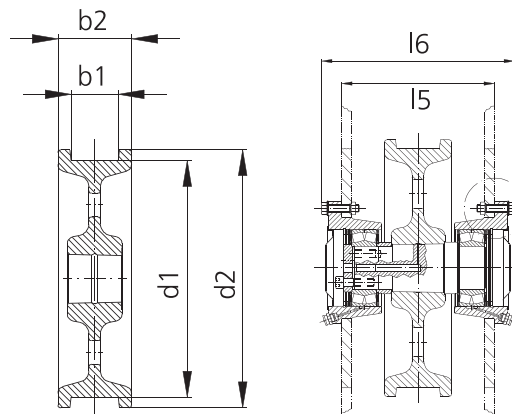

39399-2

Complete industrial drive solutions from wheels to inverters



21564

Demag conical-rotor brake motors – for increased requirements such as extremely high switching frequencies and braking operation for line-controlled drives; outputs ranging from 0.37 to 42 kW



21568-1

Demag microspeed drives – with conical-rotor brake motors; for high speed stages and positioning with high stopping accuracy; speed ratios up to 500:1



38881-1



38956-2-1-1

Demag frequency inverters Dedrive Compact and Dedrive Pro – for infinitely variable speed control of standard three-phase motors as single or groups of drives for stopping and starting applications, motor shaft output up to 500 kW, current loads from 2.4 to 60 A or from 4.2 to 544 A



36633

Demag geared motors with cylindrical rotor motors – for general drive applications, outputs from 0.18 to 45 kW with cylindrical and conical-rotor motors; as D-type helical geared motors from 90 to 5800 Nm, as W-type angular geared motors from 120 to 12000 Nm and A-type offset geared motors from 130 to 11500 Nm

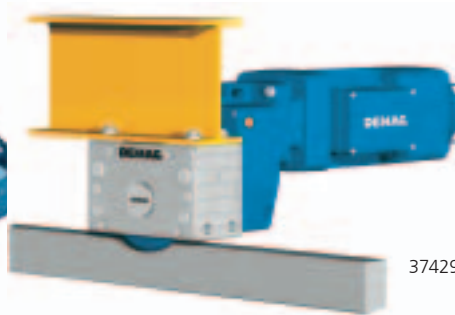

37429

Demag travel unit components – modular systems for integration into materials handling and general engineering installations and devices featuring complete travel units without the need for any additional design work and production; for wheel sets, wheel blocks, travel drives and travel units ready for installation for wheel loads up to 60 t, with many possible connections



37371-1

Demag Compact Line DCL – designed for currents up to 200 A; fitted with up to 7 conductors, as required; both for supplying mobile consumers with power as well as for transferring control signals

ELMAS S.R.L.

B-dul Grivitei nr.1Y
RO 500177 Brasov
Tel.: +40-268-308700 | 0723-362378 | 0744-350178
Fax: +40-268-308705
E-mail: office@elmas.ro
www.elmas.ro